

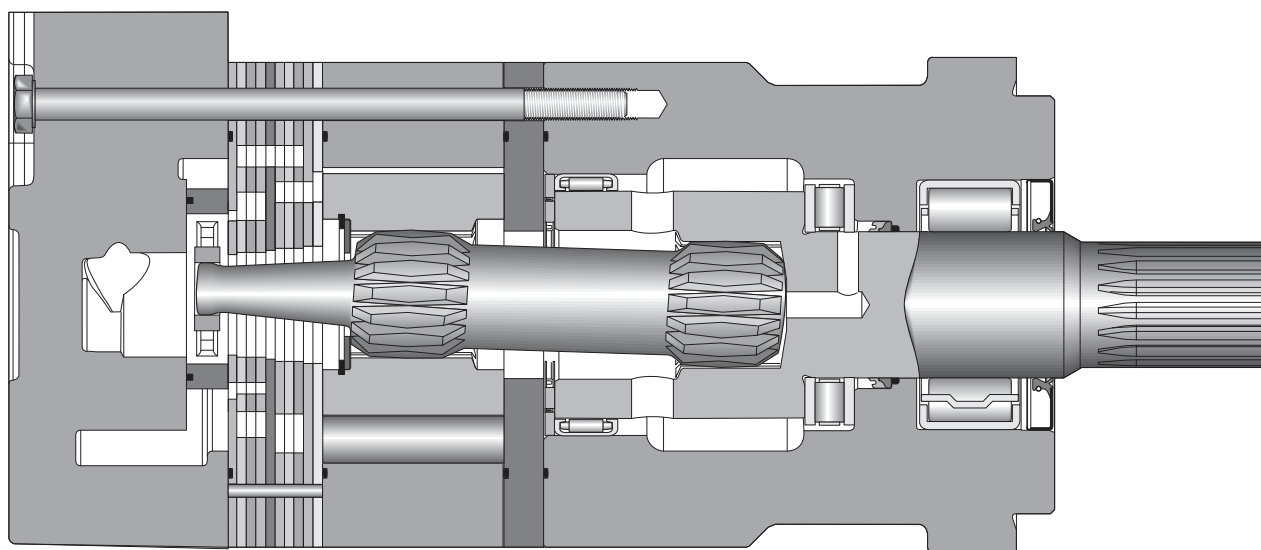

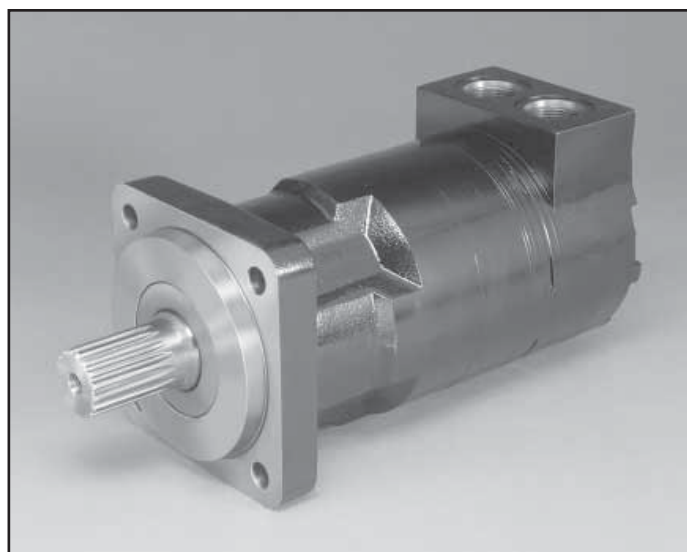

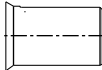





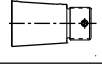
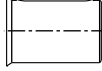
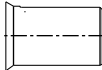

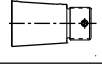
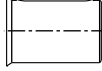
7 Displacements 7 Schluckvolumen Cylindrée 7 Desplazamientos	(15.3 to 61.0 in ³ /rev) 250 . . . 1000 cm ³ /rev	
Maximum Pressure Eingangsdruck Pression entrée Pressione in entrata	Cont. (3500 psid) . . . 241 bar	Int. (4500 psid) . . . 310 bar
Maximum Oil Flow Schluckstrom Débit d'huile Portata	(60 gpm) . . . 227 lpm	
Maximum Speed Drehzahl Velocità di rotazione Vitesse de rotation	(523 rpm) 523 rpm	
Maximum Torque MaxDrehmoment Couple Coppia	Cont. (21360 lb in) 2413 Nm	Int. (23540 lb in) 2660 Nm
Maximum Side Load at Key Seitenlast Charges latérales Carico radiale	(5900 lb) . . . 26245 N	

Exceptional Strength and Durability in a High Performance Motor

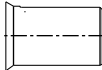
The heart of Parker's TK Series powertrain, the torque link, is an extra heavy duty part that includes patented 60:40 spline geometry. Rugged construction throughout allows the transmission of over 23,000 lb-in of torque. The entire powertrain is continually washed in cool, high flow fluid to assure long life. Roller vanes and sealed commutator maintain high efficiency and provide smooth low speed performance.

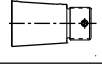
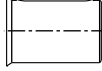

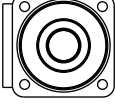
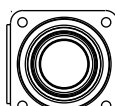
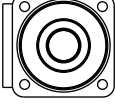
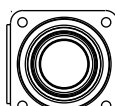
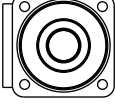
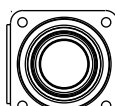
TK	XXXX	X5	XX	0	XXXX																																						
Series	Displacement Schluckvolumen Cylindrée Desplazamiento	Mounting/Rear Ports Gehäuse/Endanschluß Carter/Alimentazione Laterale Montaje/Orifices arriér	Shaft Welle Arbre Ejes	Rotation Drehrichtung Direction de rotation Rotacion	Options Opciones																																						
	<table border="1"> <thead> <tr> <th>Code</th> <th>cm³/tr cm³/giro cm³/U in³/rev</th> </tr> </thead> <tbody> <tr><td>0250</td><td>250 / 15.3</td></tr> <tr><td>0315</td><td>315 / 19.2</td></tr> <tr><td>0400</td><td>400 / 24.4</td></tr> <tr><td>0500</td><td>500 / 30.5</td></tr> <tr><td>0630</td><td>630 / 38.4</td></tr> <tr><td>0800</td><td>800 / 48.8</td></tr> <tr><td>1000</td><td>1000 / 61.0</td></tr> </tbody> </table>	Code	cm ³ /tr cm ³ /giro cm ³ /U in ³ /rev	0250	250 / 15.3	0315	315 / 19.2	0400	400 / 24.4	0500	500 / 30.5	0630	630 / 38.4	0800	800 / 48.8	1000	1000 / 61.0		<table border="1"> <thead> <tr> <th>Code</th> <th>Shaft</th> </tr> </thead> <tbody> <tr> <td>32</td> <td>1 1/2" Keyed </td> </tr> <tr> <td>36</td> <td>1 1/2" 17 Tooth 12/24 Spline </td> </tr> <tr> <td>63</td> <td>1 3/4" Tapered </td> </tr> <tr> <td>64</td> <td>40mm Keyed </td> </tr> </tbody> </table>	Code	Shaft	32	1 1/2" Keyed 	36	1 1/2" 17 Tooth 12/24 Spline 	63	1 3/4" Tapered 	64	40mm Keyed 	<table border="1"> <thead> <tr> <th>Code</th> <th>Rear Port Rotation</th> </tr> </thead> <tbody> <tr> <td>0</td> <td>Standard </td> </tr> <tr> <td>1</td> <td>Reverse Timed Manifold </td> </tr> </tbody> </table>	Code	Rear Port Rotation	0	Standard 	1	Reverse Timed Manifold 	<table border="1"> <thead> <tr> <th>Code</th> <th>Options</th> </tr> </thead> <tbody> <tr> <td>AAAB</td> <td>No Paint No lackiert</td> </tr> <tr> <td>AAAA</td> <td>Black Paint Schwarz lackiert</td> </tr> </tbody> </table>	Code	Options	AAAB	No Paint No lackiert	AAAA	Black Paint Schwarz lackiert
Code	cm ³ /tr cm ³ /giro cm ³ /U in ³ /rev																																										
0250	250 / 15.3																																										
0315	315 / 19.2																																										
0400	400 / 24.4																																										
0500	500 / 30.5																																										
0630	630 / 38.4																																										
0800	800 / 48.8																																										
1000	1000 / 61.0																																										
Code	Shaft																																										
32	1 1/2" Keyed 																																										
36	1 1/2" 17 Tooth 12/24 Spline 																																										
63	1 3/4" Tapered 																																										
64	40mm Keyed 																																										
Code	Rear Port Rotation																																										
0	Standard 																																										
1	Reverse Timed Manifold 																																										
Code	Options																																										
AAAB	No Paint No lackiert																																										
AAAA	Black Paint Schwarz lackiert																																										
	<table border="1"> <thead> <tr> <th>Code</th> <th>Mounting</th> </tr> </thead> <tbody> <tr> <td>K5</td> <td>Standard SAE CC, 1 5/16-12 SAE Rear Radial </td> </tr> <tr> <td>T5</td> <td>Wheel Mount, 1 5/16-12 SAE Rear Radial </td> </tr> </tbody> </table>	Code	Mounting	K5	Standard SAE CC, 1 5/16-12 SAE Rear Radial 	T5	Wheel Mount, 1 5/16-12 SAE Rear Radial 																																				
Code	Mounting																																										
K5	Standard SAE CC, 1 5/16-12 SAE Rear Radial 																																										
T5	Wheel Mount, 1 5/16-12 SAE Rear Radial 																																										

For other available options, see pages 261–262.

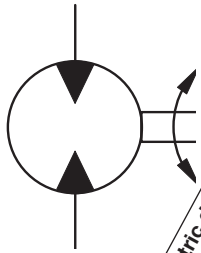

Geometric displacement
Geom. Schluckvolumen
Cylindree
Despazamientos
Max. speed @ Max. intermittent flow
Max. Drehzahl Intermitterender Betrieb:
Velocità di rotazione max Funzionement intermittente
Max. oil flow
Max. Schluckstrom
Débit d'huile maxi
Caudal Maximo de Aceite
Max. differential pressure
Max. Druckgefälle
Chute de pression maxi
Presion diferencial maxima
Max. supply pressure
Max. Eingangsdruck
Presion maxi entrée
Max. torque
Max. Drehmoment
Couple maxi
Torque Maximo
Max. performance
Max. Leistungsgabe
Maximo rendimiento
Min. starting torque
Min. Anlaufmoment
Couple min. fourni au dé manrage
Torque minimo de arranque

Motor Series TK	cm ³ /rev in ³ /rev	rev/min	cont / int* l/min g/min		cont / int* bar psid		max bar psig	cont / int* Nm lb-in		max KW HP	cont / int* Nm lb-in	
TK 0250	250 15.3	523	114 30	133 35	241 3500	310 4500	328 4750	814 7204	1043 9234	48.5 65.0	689 6100	879 7780
TK 0315	315 19.2	413	114 30	133 35	241 3500	310 4500	328 4750	1029 9105	1314 11625	47.4 63.5	949 8400	1217 10770
TK 0400	400 24.4	373	114 30	151 40	207 3000	276 4000	328 4750	1153 10201	1524 13484	48.7 65.3	1049 9280	1410 12480
TK 0500	500 30.5	298	114 30	151 40	207 3000	276 4000	328 4750	1439 12736	1914 16940	48.1 64.5	1322 11700	1783 15780
TK 0630	630 38.4	237	114 30	151 40	207 3000	224 3250	328 4750	1617 14313	1716 15187	33.7 45.2	1497 13250	1621 14350
TK 0800	800 48.8	276	151 40	227 60	190 2750	207 3000	328 4750	1916 16960	2300 20360	44.4 59.5	1745 15440	1902 16834
TK 1000	1000 61.0	218	151 40	227 60	172 2500	190 2750	328 4750	2413 21360	2660 23540	35.4 47.5	1981 17535	2180 19290

Performance data based on testing using 10W40 oil with a viscosity of 200 SUS at 54° C (130° F.) Performance data is typical. Actual data may vary slightly from one production motor to another.

Les données sur les performances sont basées sur des tests utilisant de l'huile 10W40 d'une viscosité de 200 SUS a 54°C (130°F). Ces données correspondent a des situations typiques. Les données réelles peuvent varier légèrement d'un moteur de production a l'autre.

Leistungsdaten sind gemessen mit SAE 10W40 bei einer Viskosität von 43,1 Cst bei 54°C. Geringfügige Abweichungen von den Katalogerten sind möglich.

Datos tecnicos obtenidos con aceite 10W40 de 200 SUS de viscosidad a 54°C (130°F). Los datos proporcionados son valores tipicos. Los valores exactos reales podrían tener una pequeña variación entre distintos motores.

* Intermittent operation rating applies to 10% of every minute.
Intermittierende Werte maximal 10% von jeder Betriebsminute.
Fonctionnement interm. 10% max. de chaque minute d'utilisation.
Capacidad de funcionamiento intermitente valida para 10% por cada minuto.

TK 0250

15.3 cu in / rev

PRESSURE (PSID)

	500	1000	1500	2000	2500	3000	3500	4000	4500
.5	892 5	1838 3							
1	895 12	1834 10	2777 7	3729 5	4687 4	5366 3			
2	941 27	1922 25	2911 21	3900 19	4895 18	5614 17	6576 16	7551 15	8526 14
4	951 57	1959 55	2972 51	3988 48	5012 46	5932 43	6874 40	7824 38	8792 37
8	927 118	1960 114	2997 110	4035 107	5069 103	6121 98	7124 95	8114 92	9139 89
12	870 178	1913 174	2958 170	4008 166	5060 161	6167 155	7204 149	8221 144	9230 139
16	786 239	1841 234	2895 229	3943 224	4994 219	6147 214	7183 209	8203 205	9234 199
20	671 299	1731 294	2799 289	3855 283	4896 278	6088 272	7126 267	8159 261	9185 255
24	555 359	1600 354	2666 349	3739 342	4796 336	6001 330	7044 324	8075 319	9120 314
28	410 419	1457 416	2516 409	3585 402	4657 395	5887 388	6939 380	7967 373	8993 366
32	237 479	1294 476	2362 469	3424 462	4490 455	5747 448	6802 441	7806 434	8809 426
35	119 523	1157 522	2216 514	3296 507	4381 499	5647 492	6676 484	7661 477	8685 470

Flow (GPM)

TORQUE (LB IN) 5647
SPEED (RPM) 492

250 cc / rev

EU

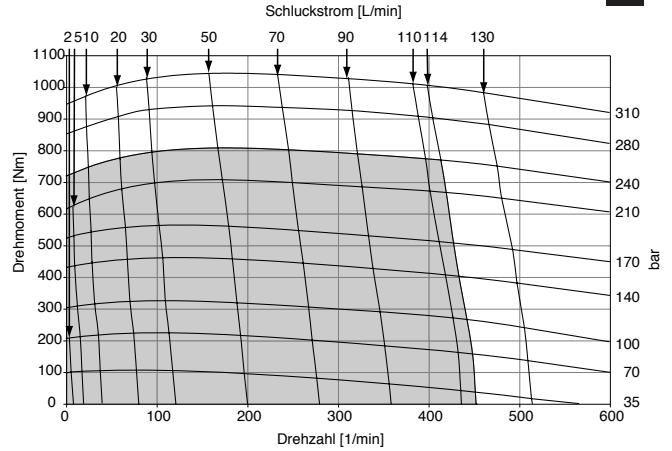

Intermittent operation rating applies to 10% of every minute.
 Fonctionnement interm. 10% max. de chaque minute d'utilisation.

Performance data based on testing using 10W40 oil with a viscosity of 200 SUS at 54° C (130° F). Performance data is typical. Actual data may vary slightly from one production motor to another.

Les données sur les performances sont basées sur des tests utilisant de l'huile 10W40 d'une viscosité de 200 SUS à 54°C (130°F). Ces données correspondent à des situations typiques. Les données réelles peuvent varier légèrement d'un moteur de production à l'autre.

017 TK.indd, js

Cont. Int. Intermittierende Werte maximal 10% von jeder Betriebsminute.

Capacidad de funcionamiento intermitente valida para 10% por cada minuto.

Leistungsdaten sind gemessen mit SAE 10W40 bei einer Viskosität von 43,1 Cst bei 54°C. Geringfügige Abweichungen von den Katalogerten sind möglich.

Datos tecnicos obtenidos con aceite 10W40 de 200 SUS de viscosidad a 54°C (130°F). Los datos proporcionados son valores tipicos. Los valores exactos reales podrian tener una pequena variacion entre distintos motores.

TK 0315

19.2 cu in / rev

PRESSURE (PSID)

	500	1000	1500	2000	2500	3000	3500	4000	4500
.5	1105 5	2300 4	3519 3						
1	1161 11	2342 9	3567 9	4786 8	6035 8	7319 7			
2	1210 22	2468 21	3728 20	4992 19	6222 18	7454 17	8675 16	9899 15	1104 14
4	1224 46	2512 43	3803 41	5094 39	6363 37	7623 35	8875 33	10108 31	11337 30
8	1201 94	2524 91	3853 89	5183 86	6498 83	7799 80	9084 78	10343 77	11587 76
12	1128 142	2458 137	3791 133	5134 130	6469 127	7793 124	9105 121	10383 118	11625 117
16	1021 189	2358 184	3702 179	5045 176	6390 172	7724 168	9043 164	10340 161	11601 159
20	890 237	2227 232	3580 226	4931 222	6278 218	7620 214	8942 210	10245 205	11520 201
24	739 284	2067 280	3419 273	4771 268	6123 263	7470 259	8798 254	10099 249	11374 244
28	586 331	1904 327	3249 320	4605 314	5953 309	7296 304	8636 300	9937 293	11222 289
32	397 377	1721 374	3087 367	4420 361	5757 355	7100 350	8447 346	9766 339	11057 332
35	240 413	1558 410	2897 403	4257 395	5606 389	6943 383	8284 378	9593 371	10888 367

Flow (GPM)

TORQUE (LB IN) 6943
SPEED (RPM) 383

315 cc / rev

EU

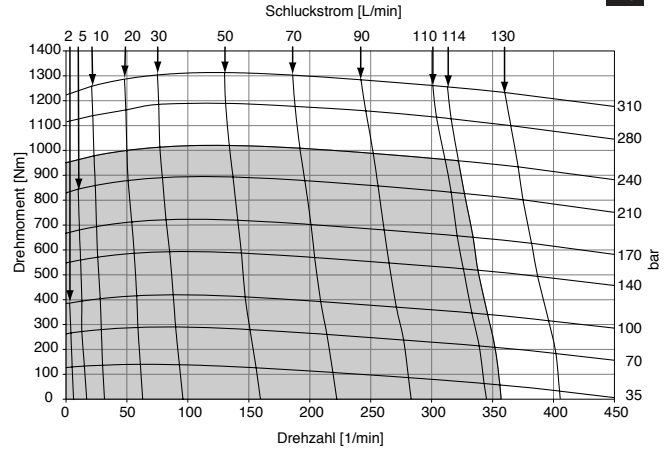

Intermittent operation rating applies to 10% of every minute.
Fonctionnement interm. 10% max. de chaque minute d'utilisation.
Performance data based on testing using 10W40 oil with a viscosity of 200 SUS at 54° C (130° F). Performance data is typical. Actual data may vary slightly from one production motor to another.
Les donnees sur les performances sont basees sur des tests utilisant de l'huile 10W40 d'une viscosite de 200 SUS a 54°C (130°F). Ces donnees correspondent a des situations typiques. Les donnees reelles peuvent varier legerement d'un moteur de production a l'autre.
017 TK.indd, js

Cont. Int.
Intermittierende Werte maximal 10% von jeder Betriebsminute.
Caacidad de funcionamiento intermitente valida para 10% por cada minuto.
Leistugsdaten sind gemessen mit SAE 10W40 bei einer Viskositaet von 43,1 Cst beo 54°C. Geringfuegige Abweichungen von den Katalogerten sond moeglich.
Datos tecnicos obtenidos con aceite 10W40 de 200 SUS de viscosidad a 54°C (130°F). Los datos proporcionados son valores tipcos. Los valores exactos reales podrian tener una pequena variacion entre distintos motores.

TK 0400

24.4 cu in / rev

PRESSURE (PSID)

	500	1000	1500	2000	2500	3000	3500	4000
.5	1429 4	2974 3	4559 3	6201 2	7860 2	9483 2	11110 2	12511 1
1	1498 8	3029 8	4566 7	6173 6	7829 6	9479 5	11101 5	12648 4
2	1586 17	3211 15	4835 14	6466 13	8043 12	9590 11	11206 10	12865 9
4	1620 36	3295 34	4974 32	6652 29	8321 28	9962 26	11582 25	13052 23
8	1615 73	3334 70	5062 68	6790 65	8488 63	10160 60	11825 58	13301 56
12	1536 110	3282 107	5025 105	6764 101	8493 98	10201 95	11893 92	13462 89
16	1418 148	3171 144	4924 141	6676 138	8421 134	10150 130	11846 127	13484 123
20	1270 185	3022 181	4776 178	6537 174	8296 170	10037 166	11744 161	13432 157
24	1095 222	2846 219	4601 215	6371 210	8135 206	9876 201	11610 197	13405 192
28	907 259	2645 256	4397 251	6171 247	7937 242	9681 237	11430 232	13250 228
32	683 297	2420 293	4179 288	5951 283	7714 278	9467 273	11211 268	12923 262
35	501 325	2216 322	4007 316	5779 311	7529 306	9280 300	11020 294	12745 289
40	195 373	1908 368	3649 362	5417 357	7193 351	8961 345	10703 339	12390 332

Flow (GPM)

TORQUE (LB IN) 8961
SPEED (RPM) 345

400 cc / rev

EU

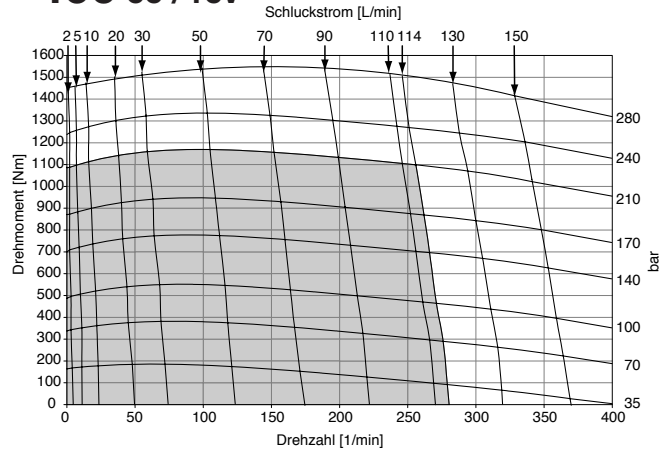

Intermittent operation rating applies to 10% of every minute.
Fonctionnement interm. 10% max. de chaque minute d'utilisation.

Performance data based on testing using 10W40 oil with a viscosity of 200 SUS at 54° C (130° F). Performance data is typical. Actual data may vary slightly from one production motor to another.

Les donnees sur les performances sont basees sur des tests utilisant de l'huile 10W40 d'une viscosite de 200 SUS a 54°C (130°F). Ces donnees correspondent a des situations typiques. Les donnees reelles peuvent varier legerement d'un moteur de production a l'autre.

Cont.

Int.

Intermittierende Werte maximal 10% von jeder Betriebsminute.

Capacidad de funcionamiento intermitente valida para 10% por cada minuto.

Leistungsdaten sind gemessen mit SAE 10W40 bei einer Viskosität von 43,1 Cst bei 54°C. Geringfügige Abweichungen von den Katalogerten sind möglich.

Datos tecnicos obtenidos con aceite 10W40 de 200 SUS de viscosidad a 54°C (130°F). Los datos proporcionados son valores tipicos. Los valores exactos reales podrian tener una pequena variacion entre distintos motores.

TK 0500

30.5 cu in / rev

PRESSURE (PSID)

	500	1000	1500	2000	2500	3000	3500	4000
1	1880 5	3810 4	5826 3	7926 2	9000 2	11979 2	14077 1	16261 1
2	1982 13	4013 11	6067 9	8109 8	10154 6	12243 5	14323 5	16394 5
4	2000 28	4103 26	6223 24	8346 22	10464 20	12559 18	14642 16	16615 14
8	1971 58	4118 56	6276 53	8437 50	10584 48	12724 45	14852 44	16825 40
12	1876 91	4041 87	6219 85	8400 80	10575 77	12736 73	14873 70	16901 66
16	1724 120	3904 115	6088 112	8277 109	10461 103	12633 101	14801 97	16940 93
20	1537 148	3725 145	5911 142	8105 138	10301 134	12494 130	14660 125	16783 121
24	1318 178	3504 175	5694 171	7898 167	10108 163	12310 159	14481 154	16607 149
28	1066 208	3242 205	5430 200	7634 196	9856 192	12063 188	14232 182	16405 177
32	781 238	2959 235	5146 230	7357 225	9580 221	11781 217	13939 211	16110 206
35	551 260	2702 258	4940 252	7153 248	9335 243	11517 239	13703 233	15892 228
40	178 298	2341 296	4519 290	6746 285	8957 280	11041 275	13296 269	15400 264

Flow (GPM)

TORQUE (LB IN) 11041
SPEED (RPM) 275

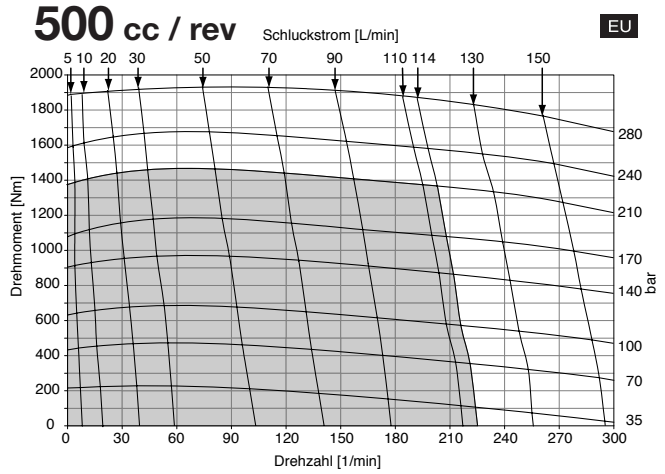

Intermittent operation rating applies to 10% of every minute.
Fonctionnement interm. 10% max. de chaque minute d'utilisation.

Performance data based on testing using 10W40 oil with a viscosity of 200 SUS at 54° C (130° F). Performance data is typical. Actual data may vary slightly from one production motor to another.

Les données sur les performances sont basées sur des tests utilisant de l'huile 10W40 d'une viscosité de 200 SUS à 54°C (130°F). Ces données correspondent à des situations typiques. Les données réelles peuvent varier légèrement d'un moteur de production à l'autre.

017 TK.indd, js

Intermittierende Werte maximal 10% von jeder Betriebsminute.

Caacidad de funcionamiento intermitente valida para 10% por cada minuto.

Leistungsdaten sind gemessen mit SAE 10W40 bei einer Viskosität von 43,1 Cst bei 54°C. Geringfügige Abweichungen von den Katalogerten sind möglich.

Datos tecnicos obtenidos con aceite 10W40 de 200 SUS de viscosidad a 54°C (130°F). Los datos proporcionados son valores típicos. Los valores exactos reales podrían tener una pequeña variación entre distintos motores.

Cont.

Int.

TK 0630

38.4 cu in / rev

PRESSURE (PSID)

	500	1000	1500	2000	2500	3000	3250
1	2319 4	4638 2	6993 2	9395 1			
2	2431 10	4839 8	7230 7	9636 6	1969 5	13330 4	13946 3
4	2492 22	4992 19	7446 17	9896 15	2235 14	13800 13	14516 11
8	2475 45	5116 42	7670 39	10180 36	2504 33	14216 31	15003 29
12	2323 69	5027 66	7694 62	10275 57	2614 53	14253 50	15147 46
16	2106 94	4850 90	7572 85	10229 79	2659 74	14290 70	15187 65
20	1885 118	4638 114	7390 109	10092 102	2609 97	14313 91	15095 85
25	1455 147	4261 143	7110 136	9946 129	2528 119	14268 111	15068 104
30	969 177	3737 175	6596 168	9451 161	2111 152	14113 142	15044 133
32	751 189	3508 187	6330 181	9201 174	1909 165	14028 154	15018 144
40	121 237	2592 235	5266 233	8201 226	1101 217	13504 205	14912 191

Flow (GPM)

TORQUE (LB IN) 13504
SPEED (RPM) 205

630 cc / rev

EU

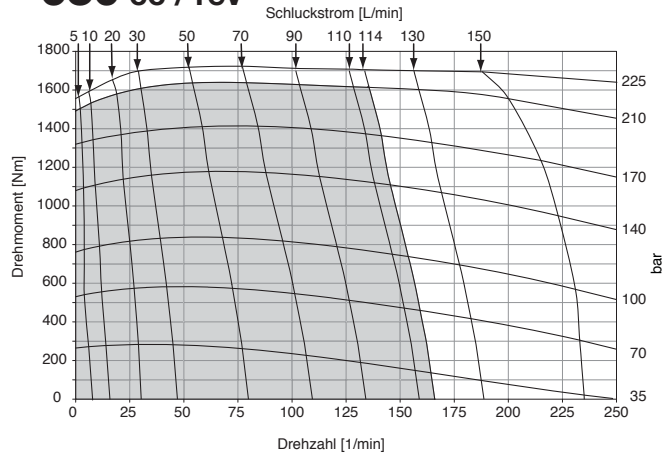

Intermittent operation rating applies to 10% of every minute.
Fonctionnement interm. 10% max. de chaque minute d'utilisation.

Performance data based on testing using 10W40 oil with a viscosity of 200 SUS at 54° C (130° F). Performance data is typical. Actual data may vary slightly from one production motor to another.

Les données sur les performances sont basées sur des tests utilisant de l'huile 10W40 d'une viscosité de 200 SUS à 54°C (130°F). Ces données correspondent à des situations typiques. Les données réelles peuvent varier légèrement d'un moteur de production à l'autre.

Cont.

Int.

Intermittierende Werte maximal 10% von jeder Betriebsminute.

Capacidad de funcionamiento intermitente valida para 10% por cada minuto.

Leistungsdaten sind gemessen mit SAE 10W40 bei einer Viskosität von 43,1 Cst bei 54°C. Geringfügige Abweichungen von den Katalogerten sind möglich.

Datos tecnicos obtenidos con aceite 10W40 de 200 SUS de viscosidad a 54°C (130°F). Los datos proporcionados son valores típicos. Los valores exactos reales podrían tener una pequeña variación entre distintos motores.

TK 0800

48.8 cu in / rev

PRESSURE (PSID)

	500	1000	1500	2000	2500	2750	3000
1	3144 4	6368 4	9714 3	13131 3	16586 3	18303 3	20020 3
2	3254 9	6589 8	9957 8	13355 7	16783 7	18511 7	20239 7
4	3313 18	6721 17	10131 17	13531 16	16926 15	18632 15	20338 15
8	3267 37	6707 36	10146 35	13561 33	16961 32	18661 32	20360 31
12	3105 55	6564 54	10011 53	13436 51	16832 49	18512 48	20191 47
16	2817 74	6316 73	9812 71	13263 68	16678 66	18380 65	20082 64
20	2530 93	6046 91	9530 89	12963 86	16392 84	18099 83	19806 81
24	2153 112	5637 109	9156 107	12636 104	16060 101	17758 100	19456 99
28	1741 130	5226 128	8766 125	12213 122	15621 119	17339 118	19057 116
32	1302 149	4774 147	8267 144	11748 140	15196 137	16885 136	18574 134
35	941 162	4411 161	7913 158	11363 154	14816 151	16511 149	18206 147
40	349 186	3765 184	7231 181	10684 177	14141 174	15842 172	17543 170
45	244 209	3134 208	6585 205	10019 201	13462 197	15149 195	16835 193
50	0 234	2287 232	5748 228	9207 224	12688 219	14407 218	16125 216
55		1441 256	4326 252	8356 247	12212 242	13713 241	15213 239
60			2904 276	7505 270	10677 265	12489 264	14301 262

Flow (GPM)

800 cc / rev

EU

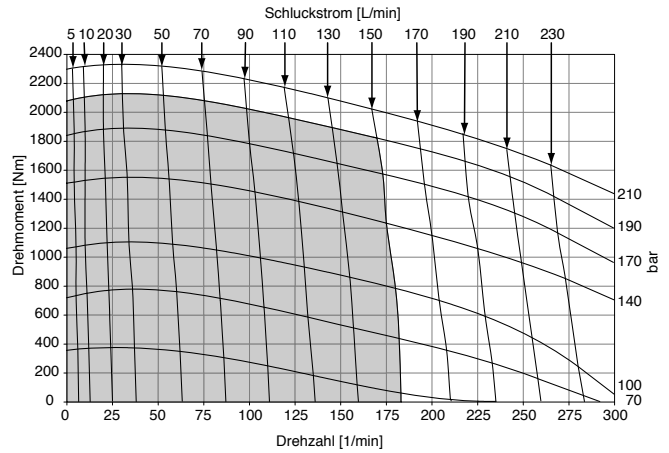

TORQUE (LB IN) 17543
SPEED (RPM) 170

Cont.

Int.

Intermittent operation rating applies to 10% of every minute.

Fonctionnement interm. 10% max. de chaque minute d'utilisation.

Performance data based on testing using 10W40 oil with a viscosity of 200 SUS at 54° C (130° F). Performance data is typical. Actual data may vary slightly from one production motor to another.

Les données sur les performances sont basées sur des tests utilisant de l'huile 10W40 d'une viscosité de 200 SUS à 54°C (130°F). Ces données correspondent à des situations typiques. Les données réelles peuvent varier légèrement d'un moteur de production à l'autre.

017 TK.indd, js

Intermittierende Werte maximal 10% von jeder Betriebsminute.

Capacidad de funcionamiento intermitente valida para 10% por cada minuto.

Leistungsdaten sind gemessen mit SAE 10W40 bei einer Viskosität von 43,1 Cst bei 54°C. Geringfügige Abweichungen von den Katalogerten sind möglich.

Datos técnicos obtenidos con aceite 10W40 de 200 SUS de viscosidad a 54°C (130°F). Los datos proporcionados son valores típicos. Los valores exactos reales podrían tener una pequeña variación entre distintos motores.

TK 1000

61.0 cu in / rev

PRESSURE (PSID)

	500	1000	1500	2000	2500	2750
1	3839 3	7926 2	12129 1	16431 1	20758 1	23100 1
2	4049 7	8269 6	12522 5	16814 4	21124 4	23195 4
4	4122 14	8406 13	12692 12	16997 11	21317 11	23477 11
8	4040 29	8378 28	12711 26	17031 25	21366 23	23546 23
12	3846 44	8215 42	12581 41	16899 39	21173 37	23312 36
16	3519 59	7958 57	12362 55	16690 53	20955 50	23083 50
20	3168 74	7615 72	12006 70	16369 67	20683 64	22750 63
24	2705 89	7132 87	11594 85	15965 82	20245 78	22358 77
28	2173 104	6629 102	11088 100	15457 96	19776 93	21883 92
32	1627 119	6008 117	10463 114	14911 111	19230 107	21354 105
35	1170 130	5568 129	9988 126	14376 123	18768 119	20921 117
40	399 149	4732 148	9133 145	13544 142	17944 138	20093 136
45	0 169	3802 167	8071 164	12397 161	16791 157	18963 155
50	0 187	2733 186	6958 183	11168 179	15338 175	17376 174
55		1502 205	5845 202	9939 198	13985 194	15973 191
60			4732 218	8710 215	12632 213	14202 211

Flow (GPM)

1000 cc / rev

Schluckstrom [L/min]

EU

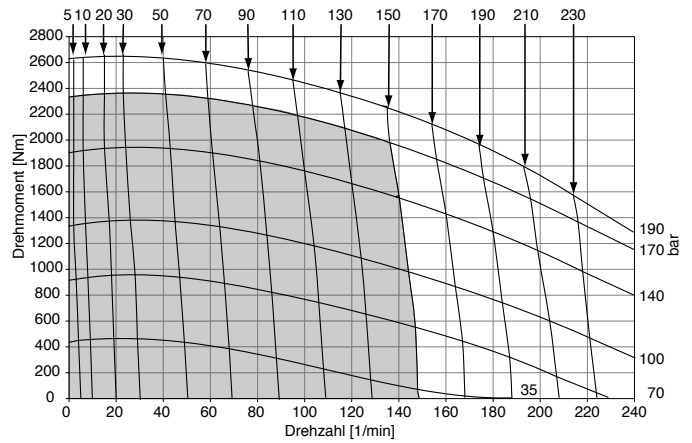

TORQUE (LB IN) 20093
SPEED (RPM) 136

Intermittent operation rating applies to 10% of every minute.
Fonctionnement interm. 10% max. de chaque minute d'utilisation.

Performance data based on testing using 10W40 oil with a viscosity of 200 SUS at 54° C (130° F). Performance data is typical. Actual data may vary slightly from one production motor to another.

Les donnees sur les performances sont basees sur des tests utilisant de l'huile 10W40 d'une viscosite de 200 SUS a 54°C (130°F). Ces donnees correspondent a des situations typiques. Les donnees reelles peuvent varier legerement d'un moteur de production a l'autre.

■ Cont.

□ Int.

Intermittierende Werte maximal 10% von jeder Betriebsminute.

Capacidad de funcionamiento intermitente valida para 10% por cada minuto.

Leistungsdaten sind gemessen mit SAE 10W40 bei einer Viskositäet von 43,1 Cst bei 54°C. Geringfügige Abweichungen von den Katalogerten sind möglich.

Datos tecnicos obtenidos con aceite 10W40 de 200 SUS de viscosidad a 54°C (130°F). Los datos proporcionados son valores tipicos. Los valores exactos reales podrian tener una pequena variacion entre distintos motores.

Flange Mount / Standardgehäuse
Monture à bride(s) / Montaje de brida

Side Load - N (lbs)

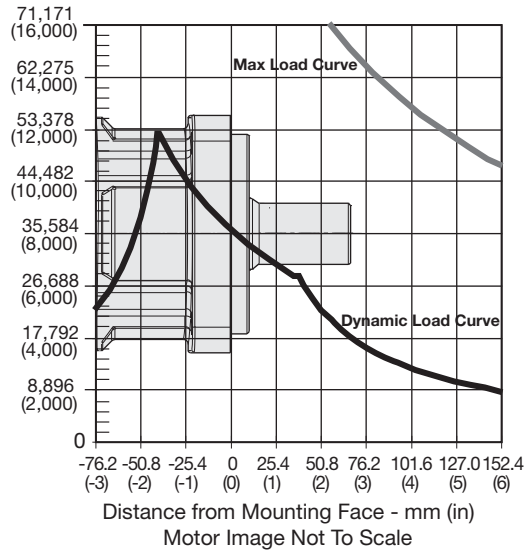

The dynamic side load curve is based on uni-directional steady state loads for L_{10} bearing life at 12×10^6 @ 100 RPM revolutions.
 Die zulaessige auslegbare radiale Wellenbelastungskurve ist unter ruhenden, einseitig statisch gerichteten Lastverhältnissen auf eine L_{10} Lebensdauer mit 12×10^6 Umdrehungen kalkuliert bei 100 min.
 La courbe de charge laterale permise se base sur des charges unidirectionnelles en regime permanent pour le roulement L_{10} a 12×10^6 @ 100 RPM revolutions.
 La curva de valores admisibles de carga lateral esta basada en cargas contantes para cojinetes L_{10} a 12×10^6 revoluciones @ 100 RPM.

Wheel Mount / Radnabengehäuse
Monture à roue / Montaje de rueda

Side Load - N (lbs)

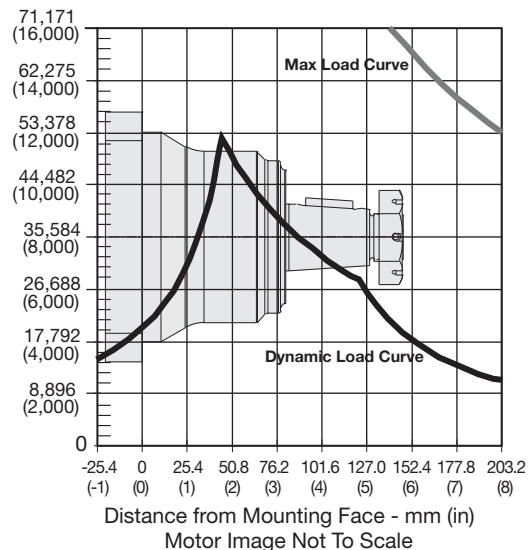

The maximum load curve is defined by bearing static load capacity. This curve should not be exceeded at any time including shock loads.
 Die maximale radiale Wellenbelastungskurve ist definiert als maximale statische Last ohne Drehzahl. Sie gilt als Grenze und sollte keinesfalls überschritten werden.
 La courbe de charge maximale est définie par la capacité de charge statique portante. Cette courbe ne devrait être dépassée en aucun moment y compris pour les charges par à-coups.
 La curva de carga máxima queda definida por la capacidad de carga estática del cojinete. No se deben superar los valores de esta curva, ni siquiera con cargas provisorias de impacto.

Equation to Calculate the Expected Radial Bearing Life
Gleichung zur Ermittlung der Lagerlebensdauer

Equation to calculate the dynamic bearing life for a given load:
 Bestimmung der erlaubten radialen Wellenbelastung mit vorgegebener Last

Use F_a , F_b and S in equation to determine hours of L_{10} bearing life.
 Die Lebensdauer in Stunden ergibt sich durch einsetzen von F_a , F_b und S in die nachstehende Formel.

$$L = \frac{12 \times 10^6}{60 \times S} \left\{ \frac{F_a}{F_b} \right\}^{3.33}$$

Where / Mit:

S = Shaft Speed RPM / Abtriebswellendrehzahl in min^{-1}

L = Life In Hours / Lebensdauer in Stunden

F_a = Allowable side load defined by above curve at a distance from mounting flange. / Erlaubte radiale Wellenbelastung als Function der Laenge

F_b = Application side load. / Anwendungsseitige Wellenbelastung

Note: Calculations are based on L_{10} bearing life per ISO 281.
 Auslegung basiert auf einer L_{10} Lebensdauer nach ISO 281.

Code: K5

Standard SAE CC, 1 5/16-12 SAE Rear Radial

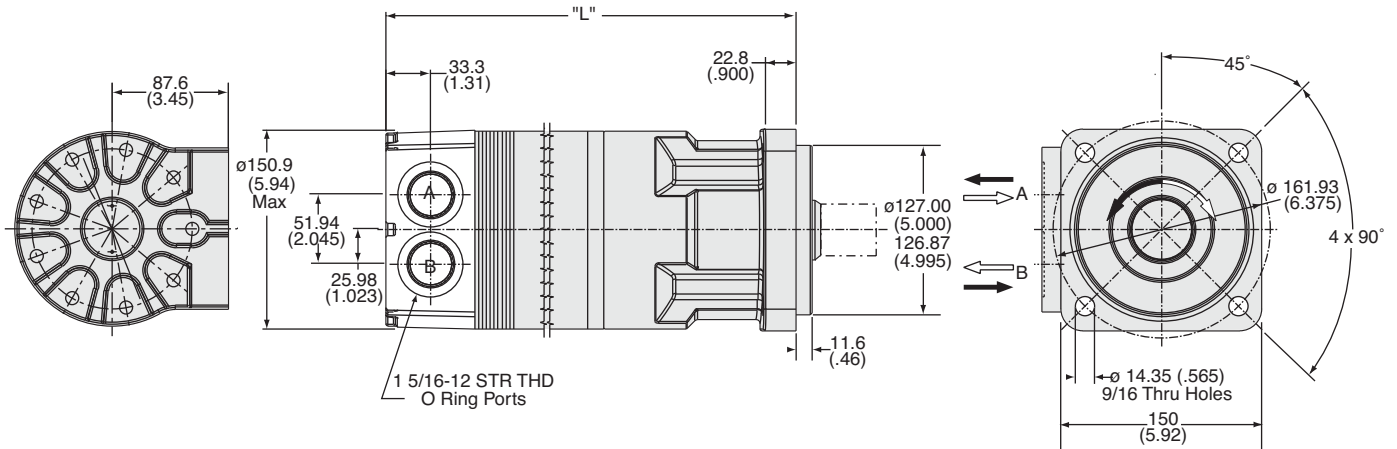

Code K5	disp.	0250	0315	0400	0500	0630	0800	1000
Weight/Gewicht	kg	32.0	32.7	33.5	34.5	35.7	37.2	39.1
Poids/Peso	(lb)	(70.6)	(72.0)	(73.8)	(76.0)	(78.8)	(82.1)	(86.3)
Length	"L" mm	277	282	290	297	310	323	340
	"L" (in)	(10.9)	(11.1)	(11.4)	(11.7)	(12.2)	(12.7)	(13.4)

Code: T5

Wheel Mount, 1 5/16-12 SAE Rear Radial

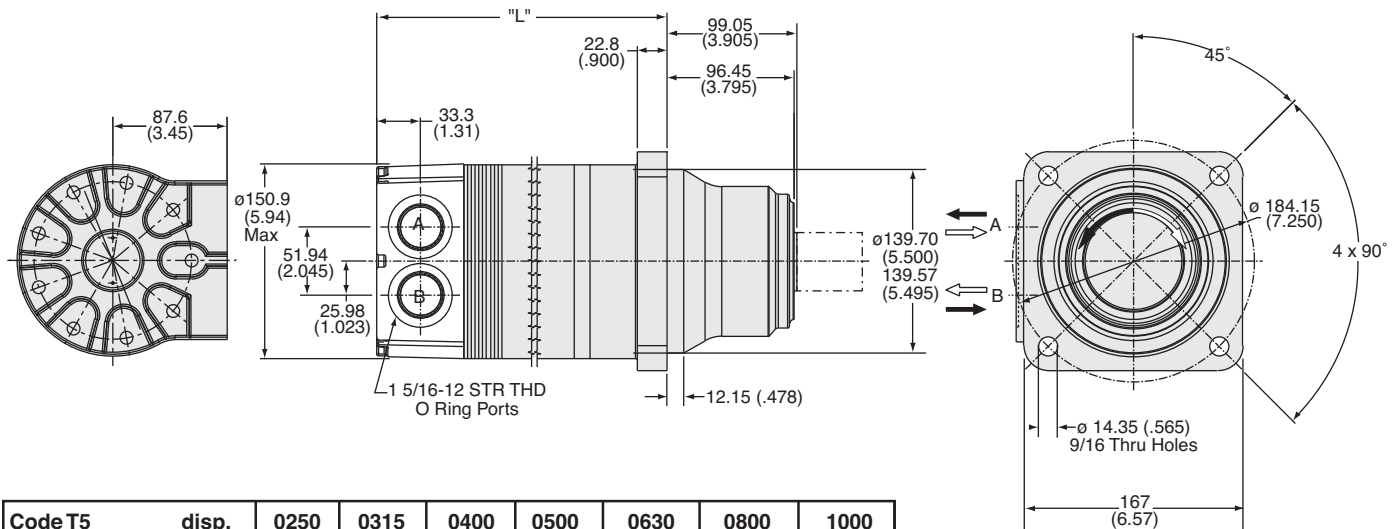

Code T5	disp.	0250	0315	0400	0500	0630	0800	1000
Weight/Gewicht	kg	30.8	31.4	32.3	33.2	34.5	36.0	37.9
Poids/Peso	(lb)	(67.9)	(69.3)	(71.1)	(73.3)	(76.1)	(79.4)	(83.5)
Length	"L" mm	191	196	203	213	224	239	257
	"L" (in)	(7.5)	(7.7)	(8.0)	(8.4)	(8.8)	(9.4)	(10.1)

English equivalents for metric specifications are shown in ().

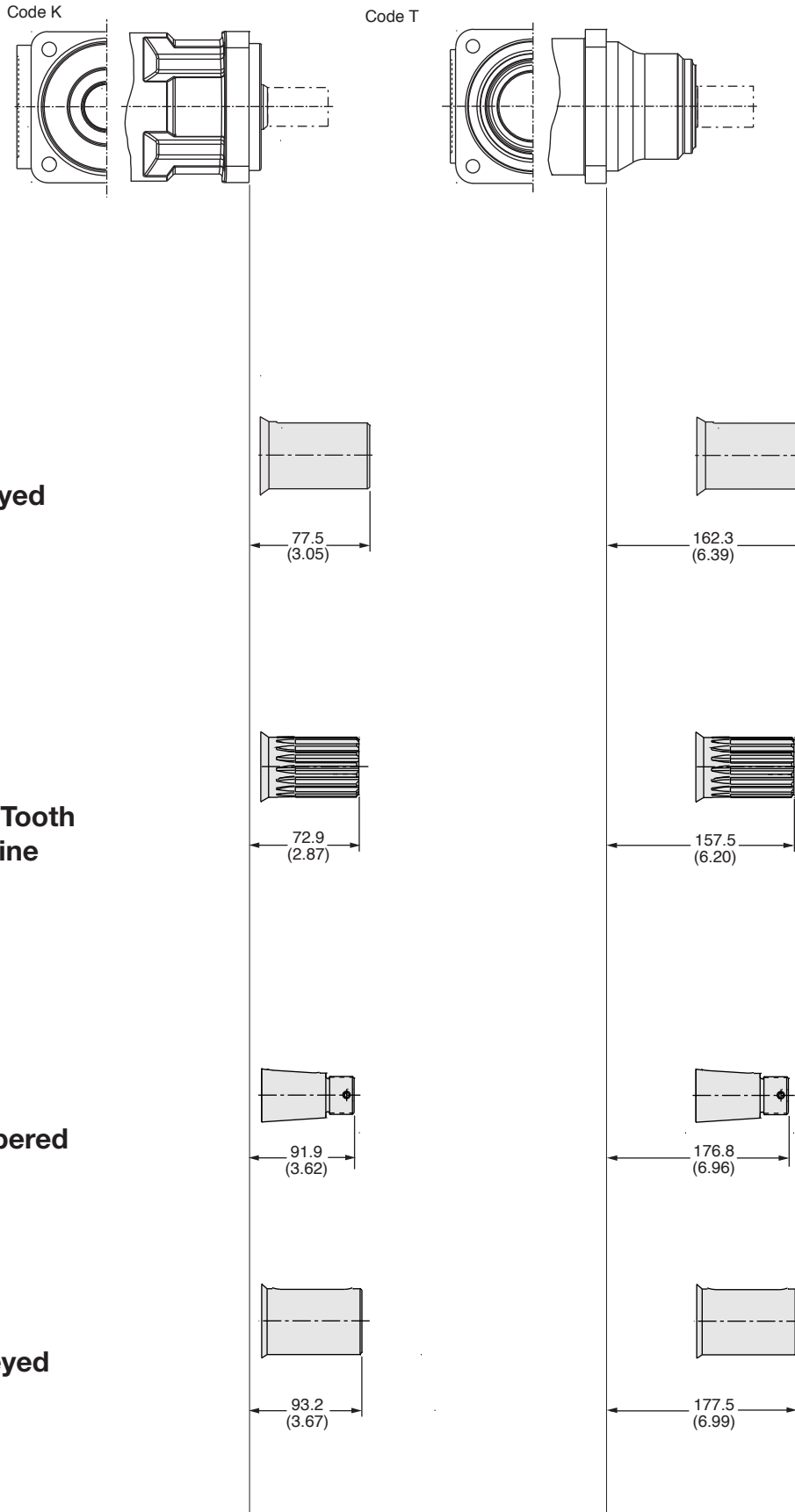

English equivalents for metric specifications are shown in ().

017 TK.indd, js

Code: 32

1 1/2" Keyed

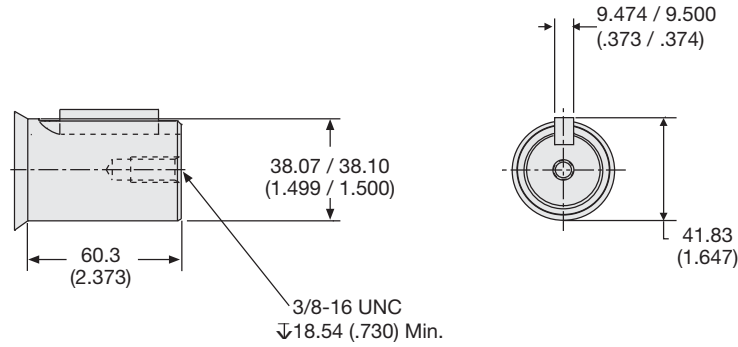

Code: 36

1 1/2" 17 Tooth
12/24 Spline

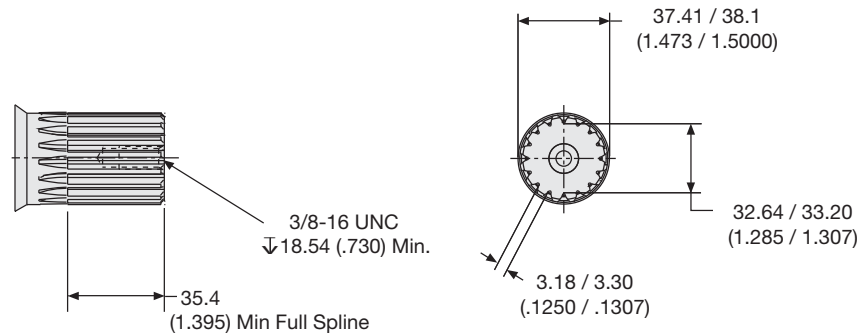

Code: 63

1 3/4" Tapered

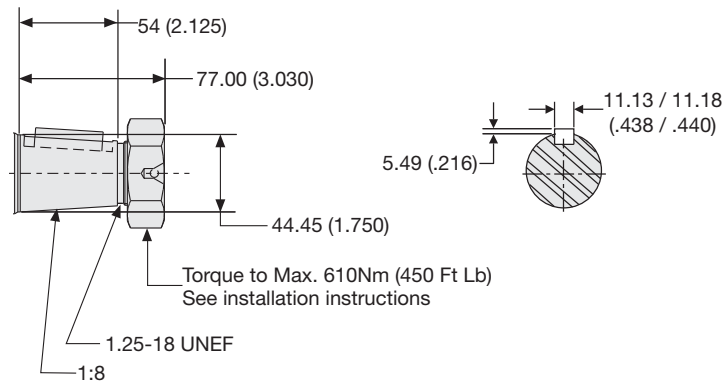

Code: 64

40mm Keyed

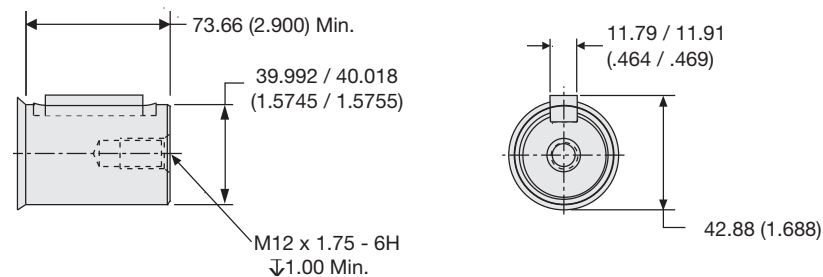

English equivalents for metric specifications are shown in ().

017 TK.indd, js